

Specifications Elan 60R

Elan Heated Towel Ladder

Model: 60R - Round

Code: ELA-7A08 (dual wiring)

Measurements

800H x 600W x 90Dmm

Width Centres 568mm

Vertical Centres 630mm

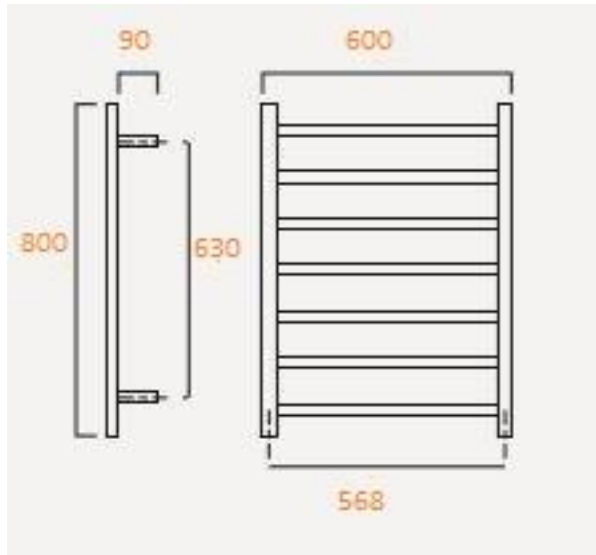

Features

7 Rails

High Mirror Polish

Quality Stainless Steel

Dual Wiring

Concealed or Exposed Wiring

Electrical Specifications

230-240v Volts ac, 50Hz

80 Watts

IP Rating 55

Complies to Standards

AS/NZS 60335.1.2012